

MULTITEL MXE200

Isuzu M21 Ground Euro6D

D68328

Ente	Rev.	Descrizione	Data	Dis.	Contr.	Ap.AQ
MRK	2	EMISSIONE	09/04/21	F.Z.		
INGOMBRO - SCHEDA 54/1 - Rev. 0 - 15/12/00						

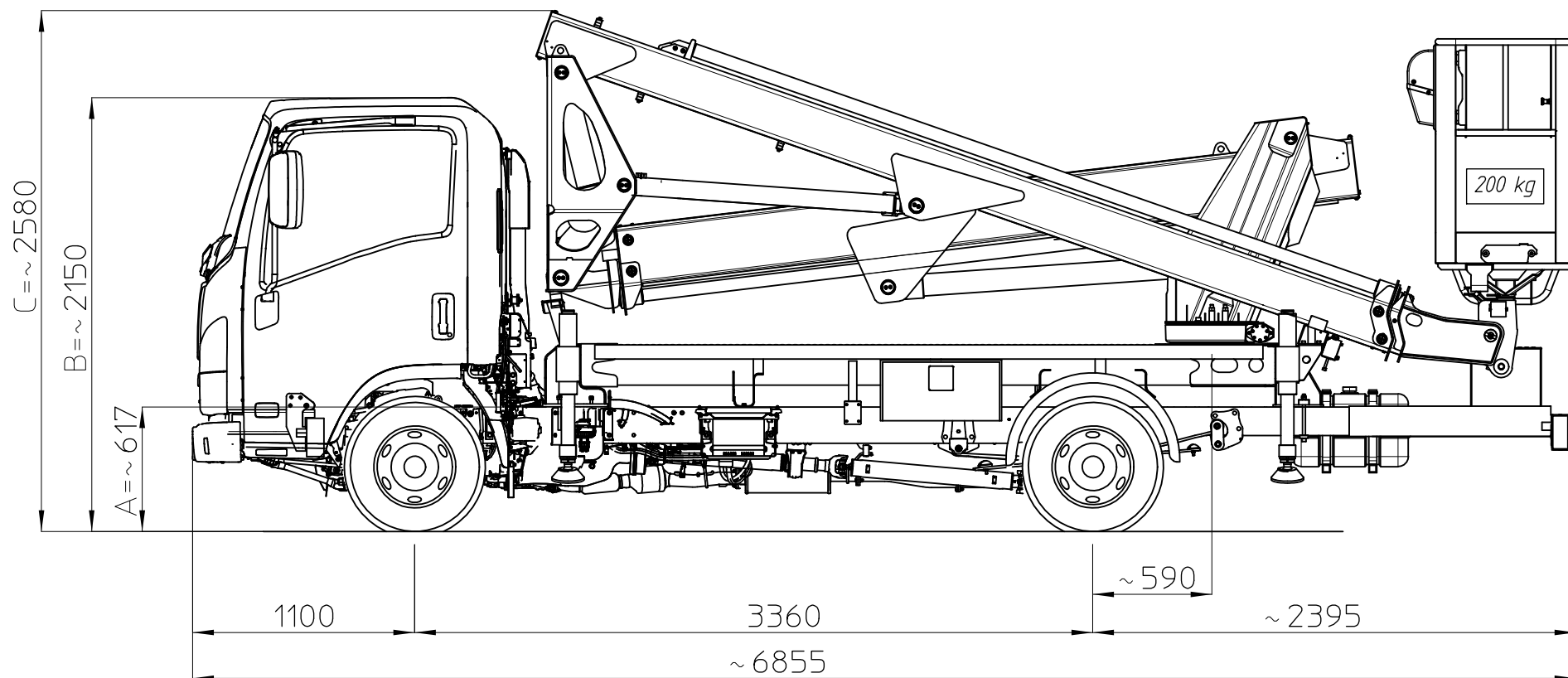

I - Le quote riportate in disegno sono indicative e possono subire variazioni. In particolare le quote A-B sono relative alle dimensioni dell'autocarro, quindi devono essere verificate sullo stesso. La quota C (altezza totale) e' subordinata alle quote A-B e non comprende eventuali parti flessibili.

F - Les cotes indiquées dans le dessin sont indicatives et peuvent subir des variations. En outre les cotes A-B sont relatives aux dimensions du porteur, donc elles doivent être vérifiées sur le porteur même. La cote C (hauteur totale) est subordonnée aux cotes A-B est indiquée hors flexibles.

E - The dimensions shown in the drawing are an indication and may undergo changes. Further the dimensions A-B are related to the truck sizes, therefore they must be verified. The dimension C (total height) is subject to A-B and does not include hoses.

D - Die Maße, die in der Zeichnung gezeigt werden, sind eine Anzeige und können Änderungen durchmachen. Die Abmessungen A-B betreffen die Fahrzeugmasse, daher sollen sie geprüft werden. Die Abmessung C (Gesamthöhe) hängt von A-B Abmessungen ab, die schlauche sind ausgeschlossen.

DIAGRAMMI DI LAVORO	TIPO DI STABILIZZAZIONE	PORTATA CESTELLO (kg)
	PIEDI IN SAGOMA	200 kg
PIEDI PARZIALI	D67593	
PIEDI ESTESI		
SOTTOPONTE		
CARICO UTILE:		
DISEGNO STABILIZZAZIONE		
AUTOCARRO	1° ASSE	2° ASSE
TARE A VUOTO:	1390 kg	535 kg
MASSIMI AMMESSI:	1900 kg	2200 kg
P.T.T.:	3500 kg	
NOTE:		

MULTITEL

MXE200

Ente	Rev.	Descrizione	Data	Dis.	Contr.	Ap.AQ
MRK	0	EMISSIONE	16/01/20	A.G.		
DIAGRAMMA - SCHEDA 54/2 - Rev. 0 - 15/12/00						

D67593

P.T.T.=3500kg
G.V.W.=3500kg
P.T.A.C.=3500kg
GES. GEWICHT=3500kg

200Kg
SBRACCIO DI LAVORO 9,0 m ±5%
WORKING OUTREACH 9,0 m ±5%
DEPORT DE TRAVAIL 9,0 m ±5%
SEITLICHE REICHWEITE 9,0 m ±5%

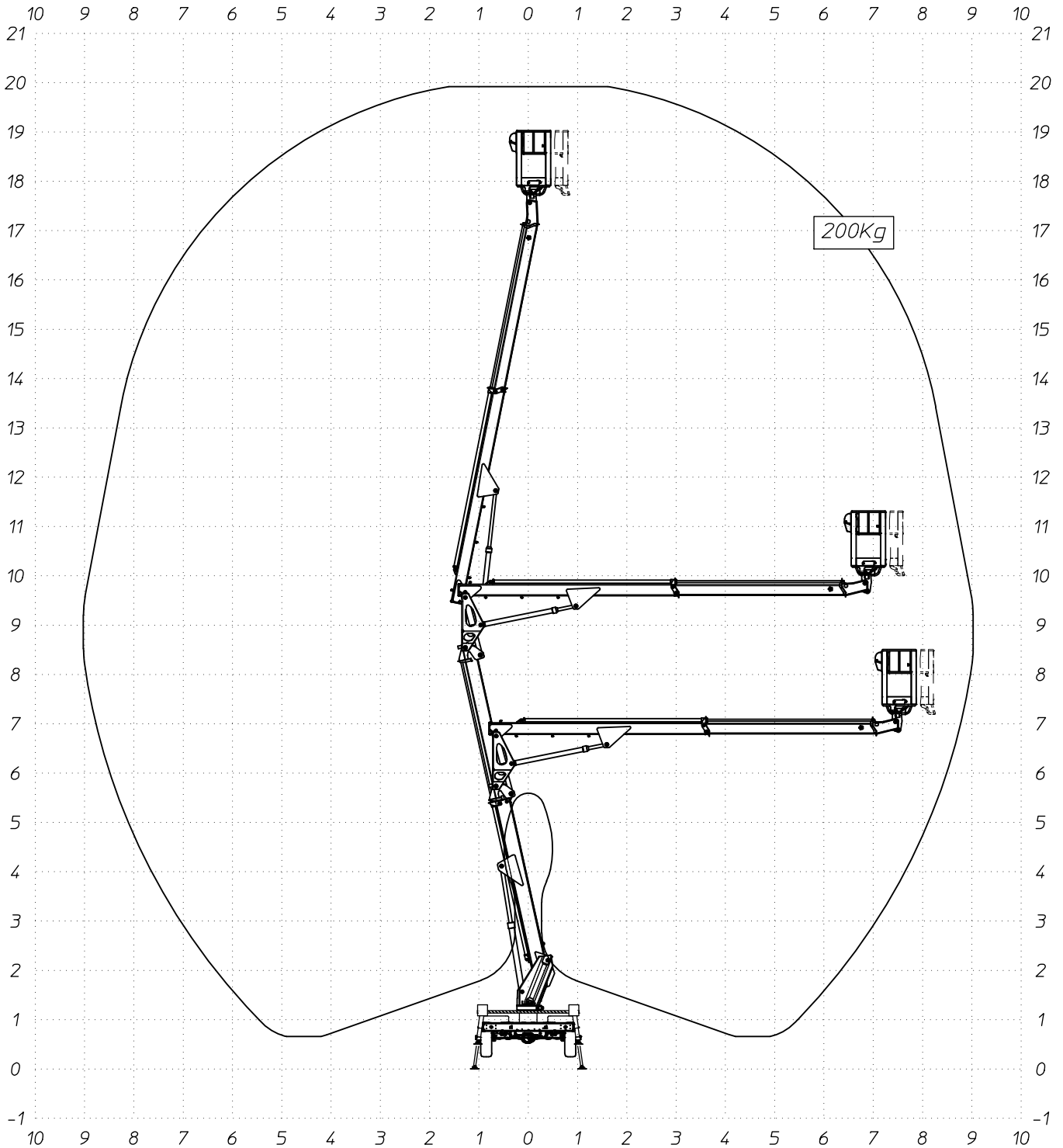



MXE 200

	19,80 m		17,80 m		9,00 m (200 kg)
	200 kg		1,4 x 0,7 x 1,10 m		65° + 65°
	380°		DS Stabilizzatori a discesa in sagoma Stabilisateurs dans le gabarit Straight line stabilizers Stützen innerhalb der Fahrzeugbreite		3,5 t

MXE200

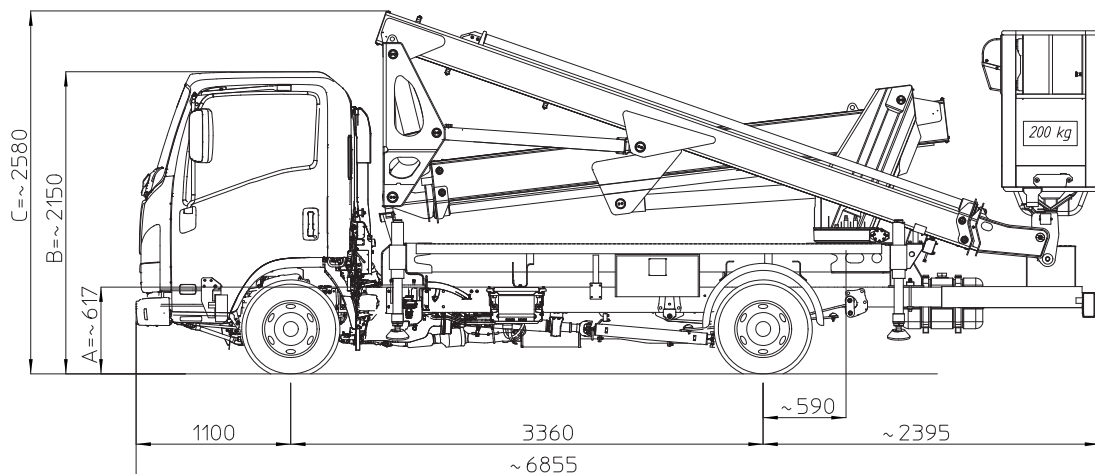
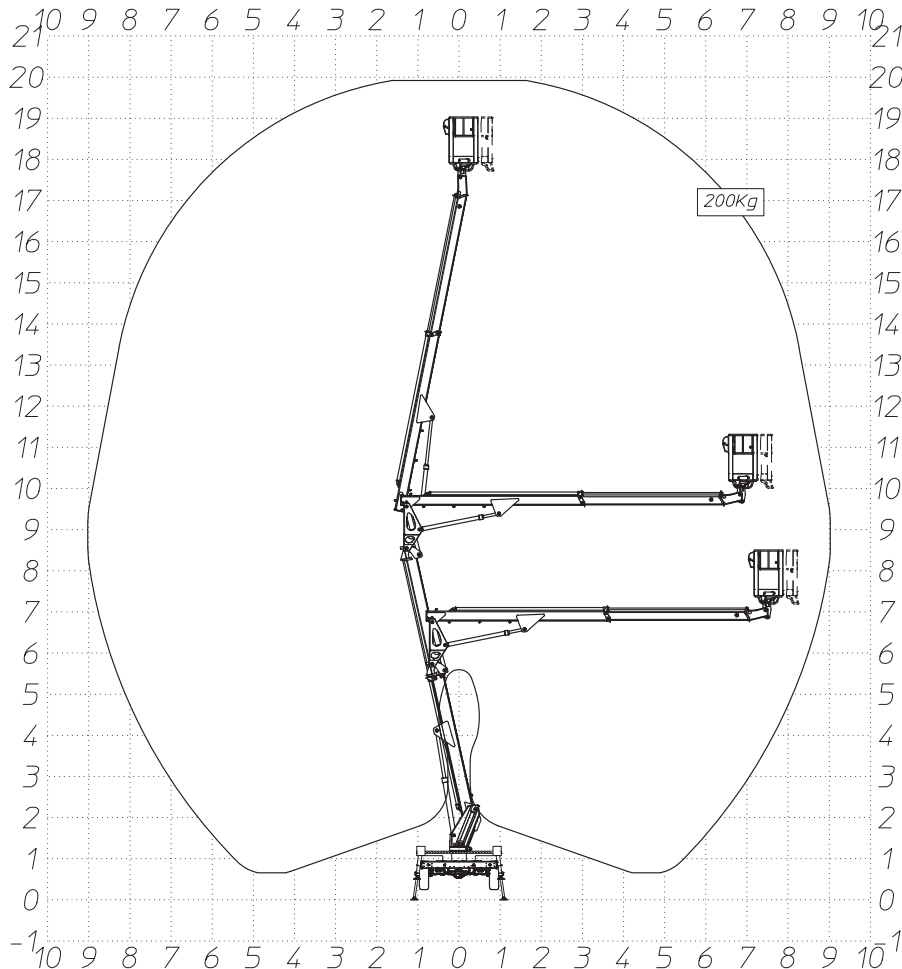

MULTITEL PAGLIERO S.P.A.

Strada Statale, 114
12030 MANTA (CN) - ITALY
Tel. +39 0175 255211- Fax +39 0175 255255
info@pagliero.com

Filiali

Corso Piemonte, 54
10099 S.MAURO T.SE (TO) - ITALY
Tel. +39 011 2236792 - Fax +39 011 2236761

Via dell'Offelera, 106
20861 BRUGHERIO (MB) - ITALY
Tel. +39 039 883393/4 - Fax +39 039 2872140

MULTITEL INTERNATIONAL SAS

87, rue du Morellon
38070 ST. QUENTIN FALLAVIER - FRANCE
Tel. +33 (0)4 74 94 63 19 - Fax +33 (0)4 74 94 46 97
info@multitelinternational.com

MULTITEL EXPORT SALES GmbH

Carl-Zeiss-Straße, 34
52477 ALSDORF - DEUTSCHLAND
Tel. +49 (0) 2404 675 580 - Fax +49 (0) 2404 675 58 29
export@pagliero.com

MULTITEL UK Ltd

c/o Simmons Gainsford
7/10 Chandos Street, Cavendish Square - London W1G 9DQ
info.uk@pagliero.com

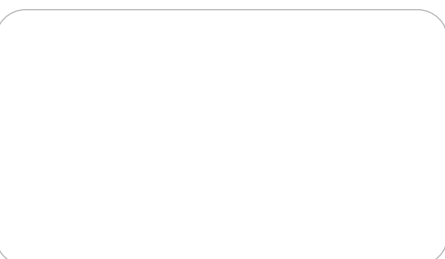

www.multitelgroup.com